

# D-206

## 2U 6 Slots Industrial PC Rackmount Chassis



### INTRODUCTION

iStarUSA 2U D-Storm D-206 industrial rackmount chassis. The special 6 butterfly slots support CompactPCI, PCI, PICMG, and ISA backplanes. Optional 3.5 and 5.25 tray enable hot-swappable storage, raid configuration, and redundant power supplies. From telecommunication to automation control system, D-206 is the most compact industrial rackmount chassis.

### FEATURES

- Ⓐ Patented Aluminum Front Panel with Locks, Taiwan: 200281 / 190240 , China: 2L01259648.5
- Ⓑ 6 Slot Butterfly Backplane
- Ⓒ Front Access USB2.0 x 2
- Ⓓ 60mm x 3 Cooling Fan
- Ⓔ Removable Air Filter
- Ⓕ Power and HDD LED
- Ⓖ Power and Alarm Reset Switch

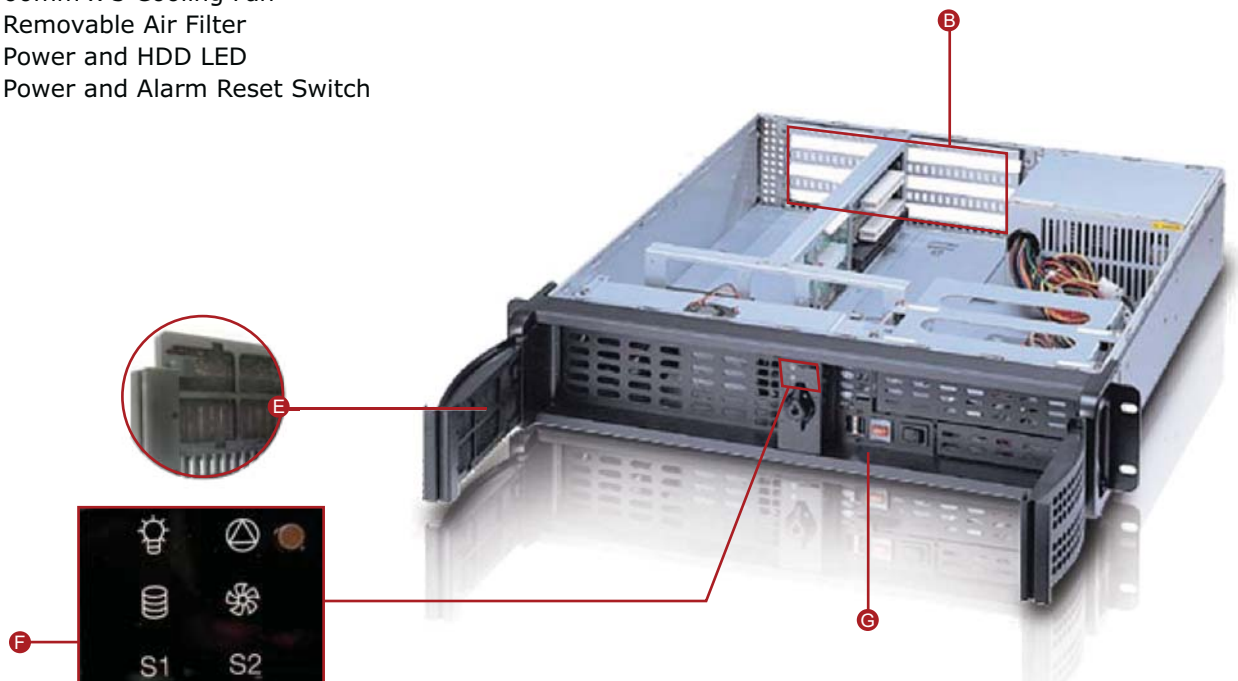

# D-206

## DRAWING

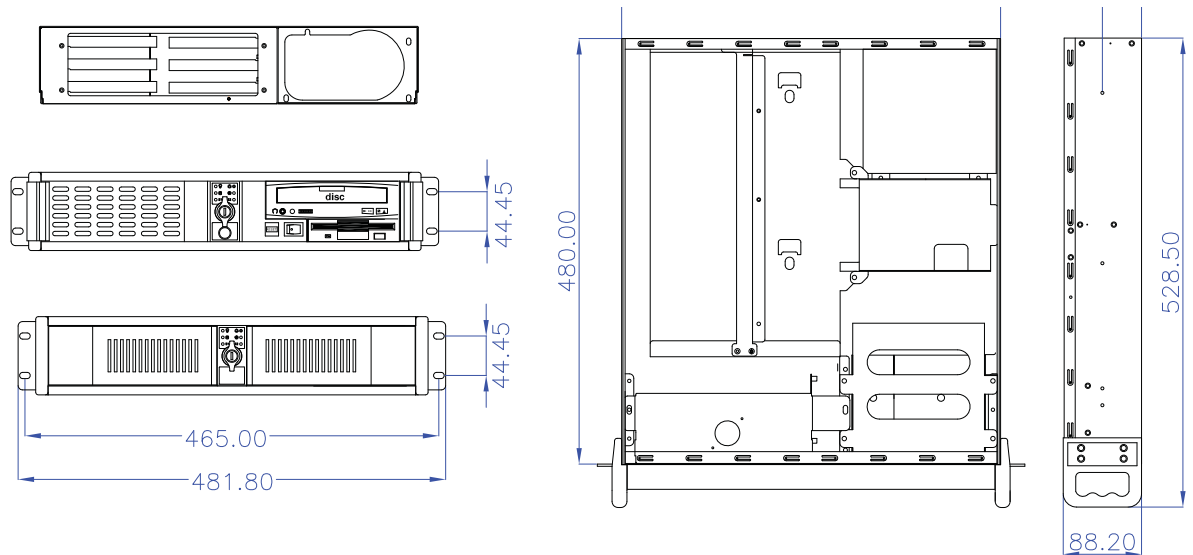

## SPECIFICATIONS

|                                |  |                                 |   |
|--------------------------------|--|---------------------------------|---|
| <b>Model Number</b>            | <b>D-206</b>   | <b>Security</b>                 | Front Bezel                               |
| <b>RoHS Compliance Version</b> | Yes  | <b>Speaker</b>                  | 0.4W Built-In                             |
| <b>Standard Drive Bays</b>     | 5.25" Drive: 1<br>3.5" Drive: 1<br>3.5 Drive [internal]: 1 | <b>Backplane</b>                | 6 Slots                                   |
| <b>Cooling Fan [Option]</b>    | 2 x 60mm [1 x 60mm]  | <b>Air Filter</b>               | Removable & Washable                      |
| <b>Mainboard Size [inch]</b>   | 12 x 10  | <b>Material of Front Bezel</b>  | Aluminum Alloy                            |
| <b>Indicators</b>              | LEDs for Power ON/OFF, HDD, Fan & Alarm                    | <b>Material of Handle</b>       | 1.2mm SECC Zinc-Coated Steel              |
| <b>Switches</b>                | Power ON/OFF, System & Alarm Reset                         | <b>Material of Main Chassis</b> | 1.2mm SECC Zinc-Coated Steel [Japan Made] |
|                                |  | <b>Color of Front Bezel</b>     | Black / Blue / Silver / Red / Gold        |
|                                |  | <b>Color of Main Chassis</b>    | Black                                     |
|                                |  | <b>Front Connector</b>          | Front USB 2.0 x 2 Connector               |
|                                |  | <b>Dimensions (WxHxD)</b>       | 19 x 3.5 x 20.8 inch                      |

## OPTIONAL ACCESSORIES

| Model Number  | Page | Model Number          | Page |
|---------------|------|-----------------------|------|
| RP-COMBO-SLIM | N/A  | DD-200-DR/DS/DBLue/DG | N/A  |
| TC-Rail-20    | 160  | RP-HDD3.5             | N/A  |
| TC-Rail-24    | 160  | T-7                   | 158  |
| TC-Rail-26    | 160  | TC-iStorm 8           | 160  |

## POWER SUPPLY OPTIONS

| Model Number          | Output           | Page |
|-----------------------|------------------|------|
| TC-350/400/500PD1     | 350/400/500W     | 230  |
| TC-600/650/700/750PD2 | 600/650/700/750W | 234  |

:: Specification and wiring diagram subject to change without notice  
 :: Limited Warranty  
 :: Last Update: Jan/2011

