



SWITCHING POWER SUPPLY SPECIFICATION

CP-02035

CLAYPOWER
C O M P A N Y

REV.00

TEL 626.303.8885 FAX 626.301.0588

727 Philips Drive City of Industry, CA 91748

www.claypower.com

1. Input Characteristics:

1.1 Input Voltage Range --- 100~240Vac, full range with active power factor 90% min

1.2 Input Frequency Range --- 47Hz to 63Hz.

1.3 Input Ac Current (Max) --- 8.0A max, full load.

1.4 Inrush Current --- At 132Vac / 264Vac, full load condition, no damage occur, input fuse shall not blow.

1.5 Efficiency ---70% min, at nominal line input full load.

1.6 Input Leakage Current --- Leakage current from line to ground will be less 10mA rms, measurement will be made at 240Vac/60Hz.

2. Output Characteristics:

2.1 Static Output Characteristics.

Output Voltage	Load Range		Regulation		Ripple Max mV P-P	Ripple & Noise Max. mV P-P
	Min.	Max.	Min.	Max.		
1. +3.3 V	0.5 A	20.0 A	- 5 %	+ 5 %	50 mV	100 mV
2. +5.0 V	0.3 A	30.0 A	- 5 %	+ 5 %	50 mV	100 mV
3. +12.0 V	1.0 A	25.0 A	- 5 %	+ 5 %	100 mV	150 mV
4. -5.0 V	0.0 A	0.5 A	- 10 %	+ 10 %	150 mV	200 mV
5. -12.0 V	0.0 A	0.5 A	- 10 %	+ 10 %	150 mV	200 mV
6. SB +5.0 V	0.0 A	3.0 A	- 5 %	+ 5 %	100 mV	100 mV

Note:

1. Noise Test --- Noise bandwidth is from Dc to 20MHz.
2. Ripple frequencies greater than 1 MHz shall be attenuated by the measurement system.
3. Add 0.1uF / 10uF capacitor at output connector terminals for ripple & noise measurements.
4. Combined total power from +3.3V and +5V rails shall not exceed 150W.
5. The total output power shall not exceed 350W.

2.2 Dynamic Output Characteristics:

2.2.1 Initial Delay Time --- NONE.

2.2.2 Rise Time --- 50 mS max, at nominal line full load.

2.2.3 Turn-on Delay Time --- 600mS max, at nominal line full load.

2.2.4 Hold-up Time --- 16mS min. for + 5V output at nominal line full load.

2.2.5 Transient Overshoot --- 10% max. of delay state after load change of 25% within the range of 50% to 100% of full load.

2.2.6 Temperature Coefficient --- 0.03% per °C max.

3. Protections:

**3.1 Over Voltage Protection --- Standard on +3.3V output set at 3.7Vdc – 4.5Vdc.
+5.0V output set at 5.7Vdc – 6.5Vdc.
+12.0V output set at 13.5Vdc – 14.5Vdc.**

3.2 Short Circuit Protection --- A short circuit placed between DC return and output shall cause no damage and the power supply shall shutdown.

3.3 Over Power Protection --- The power supply can use electronic circuit to limit the output. Power against excessing +115% - 150% of full load, or protected against excessive power delivery due to short circuit of any output or over total power.

3.4 No load Operation --- No parts damaged on power supply.

4. Dielectric Withstand Voltage:

4.1 Primary to Secondary ----- 1500Vac for 1 minute. Or 2200Vdc for 3 sec.

4.2 Primary to Safety Ground --- 1500Vac for 1 minute. Or 2200Vdc for 3 sec.

4.3 Insulation Resistance ----- Primary fo safety ground - 500Vdc, 100M ohms min.

5. Conducted EMI: Internal Filter Can Meet.

5.1 FCC Requirement --- Part15, SUB-Part J, Computing Devices “ Class B “ Limits.

5.2 VDE Requirement --- Class “ B “ (General Operating Permit) Requirements Of VFG 234/1991.

5.3 CISPR Requirement --- Class “ B “ Requirements Of CLSPR 22.

5.4 Harmonic Requirement --- IEC61000-3-2 & IEC61000-3-3 Class “ D “.

6. Product Safety: This Power Supply Is Designed Can Meet The Following Spec.

6.1 UL/CUL ----- UL60950-1

6.2 TUV ----- EN 60950-1

7. Environment:

7.1 Operation Temperature ----- Air temperature 0 °C to 50 °C.

7.2 Operation Relative Humidity ----- 20% to 90%.

7.3 Storage Temperature ----- Air temperature -20 °C to 60 °C.

7.4 Storage Relative Humidity ----- 5% to 95%.

7.5 Altitude ----- Operate properly at any altitude between 0 To 100,000 feet, storage 40,000 feet.

7.6 Vibration ----- 0.38mm. 5-55-5Hz, 1 minutes per cycle; 30 minutes for each axis (X,Y,Z).

8. Burn-In

8.1 Burn-In ----- At 45 °C, max. load, 4 hours.

9. Mean Time Between Failure ----- 60 KHrs minimum at 75% load for 25 °C ambient temperature.

10. Power-Good Signal:

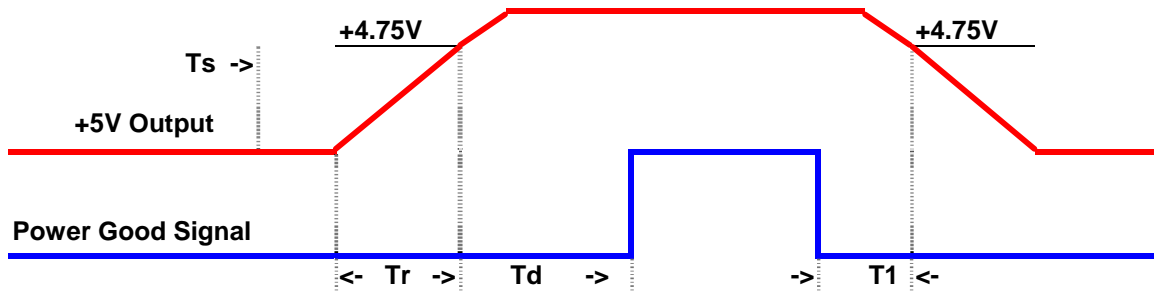

Note: $T_r \leq 100 \text{ ms}$, $T_1 \geq 1 \text{ ms}$, $T_d = 100 - 500 \text{ ms}$.

11. Dimension

11.1 W x H x D ----- 100.0 x 70.0 x 200.0 (mm)

REVISIONS			
NO	DESCRIPTION	DATE	APPROVED

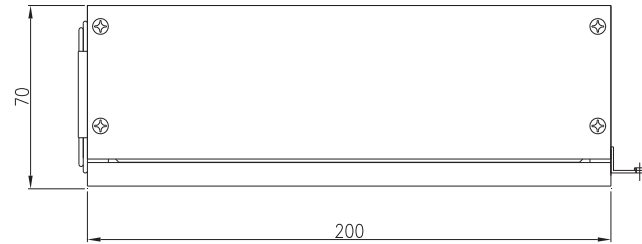
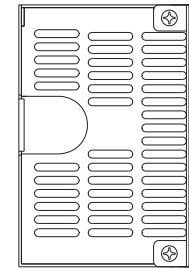
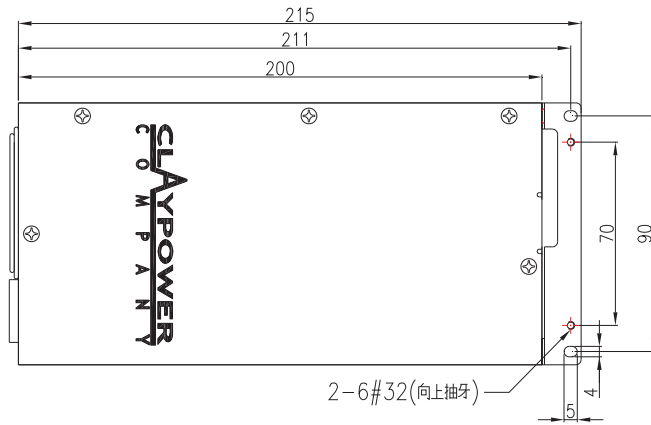
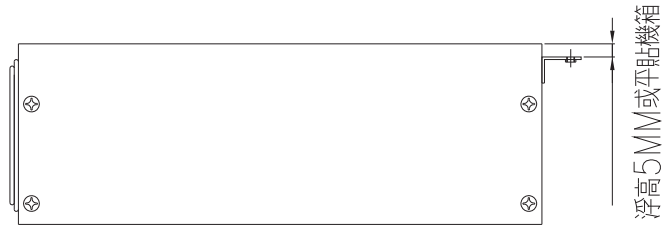
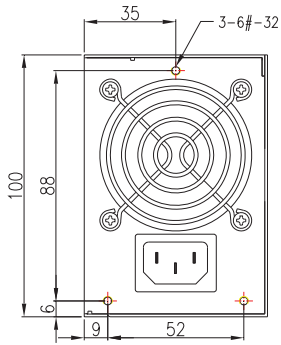

APPROVED	DATE	TITLE	PART NO.
		CP-02035	PRX 2U
CHECKED	DATE	SCALE: MM(INCHES)	DRAWING NO.
		1:2.5	PRX 2U
DESIGNED	DATE	TOLERANCES:	MODEL NO.
2008	06/18/08	.XX = ±.10 .XXX = ±.010	PRX 2U
			REV.
			A0
			SHEET
			1 of 1

第三角法 (Projection)	FINISH:	MATERIAL:		
	採購	生產	品管	

REVISIONS			
NO	DESCRIPTION	DATE	APPROVED

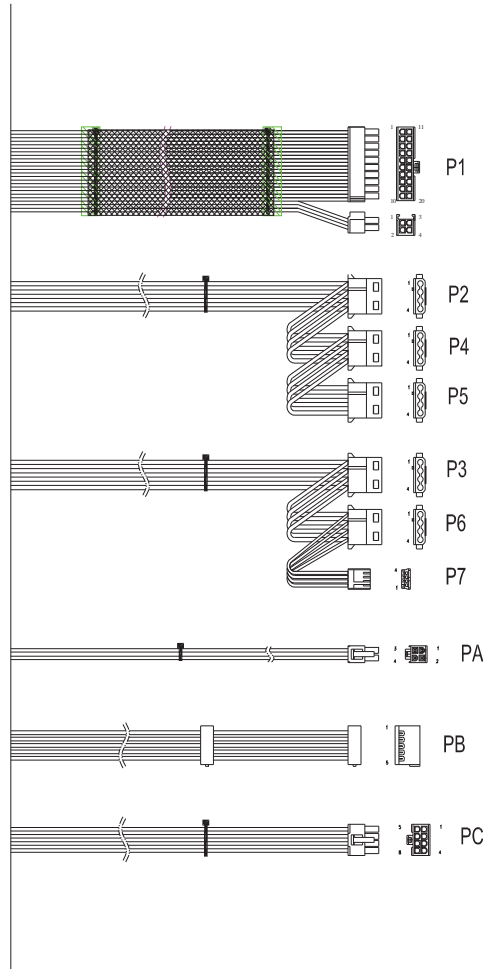

REF.ID	PIN NO.	SIGNAL	WIRE COLOR	GAUGE	CONNECTOR TYPE	LENGTH
P1	1	+3.3V	ORANGE	18	LTT/H756-20S+ LTT/H756-4S	600 ^{+50mm} -25mm
		+3.3V Sense	ORANGE	22		
	2	+3.3V	ORANGE	18		
	3	COM	BLACK	18		
	4	+5V	RED	18		
	5	COM	BLACK	18		
	6	+5V	RED	18		
	7	COM	BLACK	18		
	8	PWR OK	GRAY	22		
	9	+5VSB	PURPLE	18		
	10	+12V	YELLOW	18		
	11	+12V	YELLOW	18		
	12	+3.3V	ORANGE	18		
	13	+3.3V	ORANGE	18		
	14	-12V	BLUE	18		
	15	COM	BLACK	18		
	16	PS-ON	GREEN	22		
	17	COM	BLACK	18		
	18	COM	BLACK	18		
	19	COM	BLACK	18		
	20	-5V	WHITE	20		
	21	+5V	RED	18		
	22	+5V	RED	18		
	23	+5V	RED	18		
24	COM	BLACK	18			
P2	1	+12V	YELLOW	18	WST/P4-A10202 or equivalent	600 ^{+50mm} -25mm
P3	2	COM	BLACK	18		
	3	COM	BLACK	18		
	4	+5V	RED	18		
P4	1	+12V	YELLOW	18	WST/P4-A10202 or equivalent	150±20mm
P6	2	COM	BLACK	18		
	3	COM	BLACK	18		
	4	+5V	RED	18		
P7	1	+12V	YELLOW	22	YM/H6681-004 or equivalent	150±20mm
	2	COM	BLACK	22		
	3	COM	BLACK	22		
	4	+5V	RED	22		

PA	1	COM	BLACK	18	YM/H6657#H or equivalent	600 ^{+50mm} -25mm
	2	COM	BLACK	18		
	3	+12V	YELLOW	18		
	4	+12V	YELLOW	18		
PB	1	+3.3V	ORANGE	18	TKP/H127M2 or equivalent	600 ^{+50mm} -25mm
	2	GND	BLACK	18		
	3	+5V	RED	18		
	4	GND	BLACK	18		
	5	+12V	YELLOW	18		
PC	1	GND	BLACK	18	YM/H6657#H or equivalent	600 ^{+50mm} -25mm
	2	GND	BLACK	18		
	3	GND	BLACK	18		
	4	GND	BLACK	18		
	5	+12V	YELLOW	18		
	6	+12V	YELLOW	18		
	7	+12V	YELLOW	18		
	8	+12V	YELLOW	18		



APPROVED	DATE	TITLE	PART NO.
		CP-02035	
CHECKED	DATE	SCALE : MM(INCHES) 1:1	DRAWING NO. PRX線材圖
DESIGNED	DATE	TOLERANCES: .XX = ±.10 .XXX = ±.010	REV. A0
2008	02/27/08		SHEET 1of1

第三角法 (Projection)	FINISH:	MATERIAL:
採購	生產	品管